

Performance Vehicle Vibration Analysis

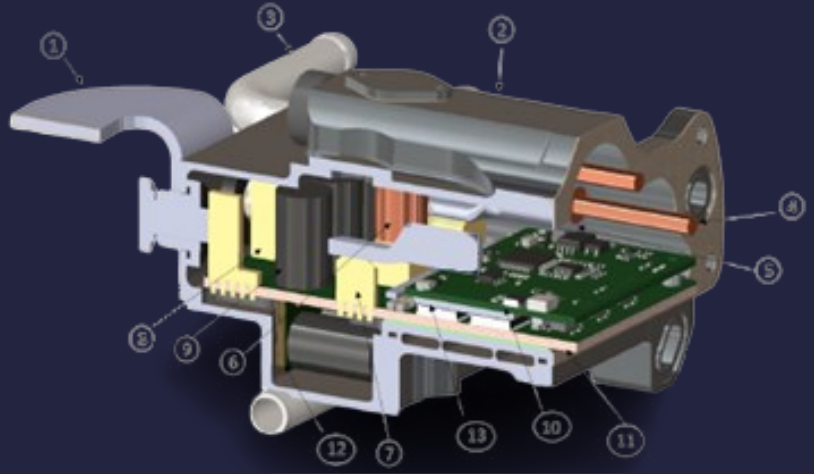

About Our Partner

Performance Projects specialises in motorsport & niche vehicle programs, utilising a core of engineering design capability with key support services in project management, built and test. They are a trusted partner for world renowned race teams seeking performance advantages.

Performance Projects are dedicated to delivering exceptionally high quality, innovative projects within agreed time frames.

Delivering Faster

Performance Projects were contracted by a motorsport partner developed a world-class vehicle to support with the design of an internal motor controller. Their aim was to provide a comprehensive delivery of the subsystem which would exceed the customer's demands while correctly managing time frames.

Performance Projects were aware that in the motorsport market, deliverable deadlines must be achieved fast as the pace of the industry is relentless. Delays to smaller components and systems may directly impact the time to market of the vehicle.

Operating as a small business, Performance Projects have outstanding expertise in their development field, but are acutely aware of the need to work with other leading experts to ensure their customer is delivered a high-quality solution.

They wanted to bring their customer confidence that the motor controller design would withstand the rigours of the operational lifecycle of the vehicle without adding the inherent time and cost of iterative testing on a prototype. In order to achieve

this, they brought in expert technical understanding on electronic packaging harshness simulations.

Performance Projects needed the capability to evaluate whether the unit will be at risk of failure during lifetime operation. Without a comprehensive drive profile and extensive vehicle chassis model, the precise loading on the controller unit would be impossible to predict.

We were able to interpret the vibration standards specified by the customer and suggest additional specifications that may be necessary. Following a brief review of the deliverables required, we identified and in fact reduced the required scope of the work thus reducing the burden of delivering data on the customer.

Creating a complex vibration profile based on the vehicle drive profile would not yield accurate results and create a significant amount of work which would likely have been waste.

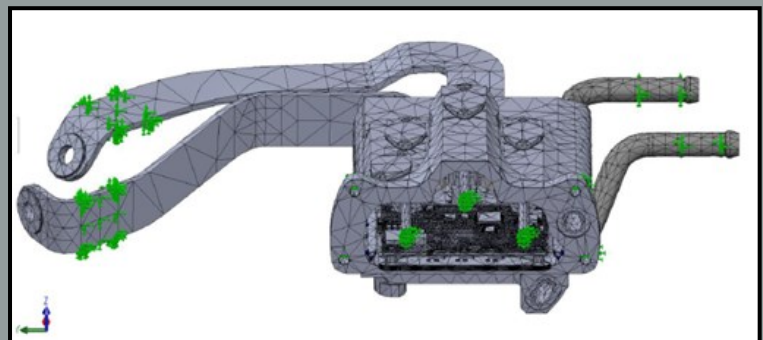

Fan Controller unit with a high density mesh over critical electronic devices and representative fixed geometry to vehicle body.

Instead, we were able to interpret the major sources of oscillating load (such as the fan motor) and their significant operating modes. By evaluating the natural operating frequencies of the motor controller and comparing with these with incident frequencies of the system, we identified and derisked the likely causes of mechanical failure well ahead of the stage the board was in layout.

Examples of de-risking methods include installing appropriate mechanical mounting point locations and specified potting requirements under critical components.

Predicting Response

With our support, Performance Projects were able to feed back invaluable engineering data to their Automotive partner on the expected load magnitudes that the unit may see during operation. With this information, they were able to progress new revisions of their board design and accelerate the time to vehicle without further unnecessary delays due to extended mechanical design.

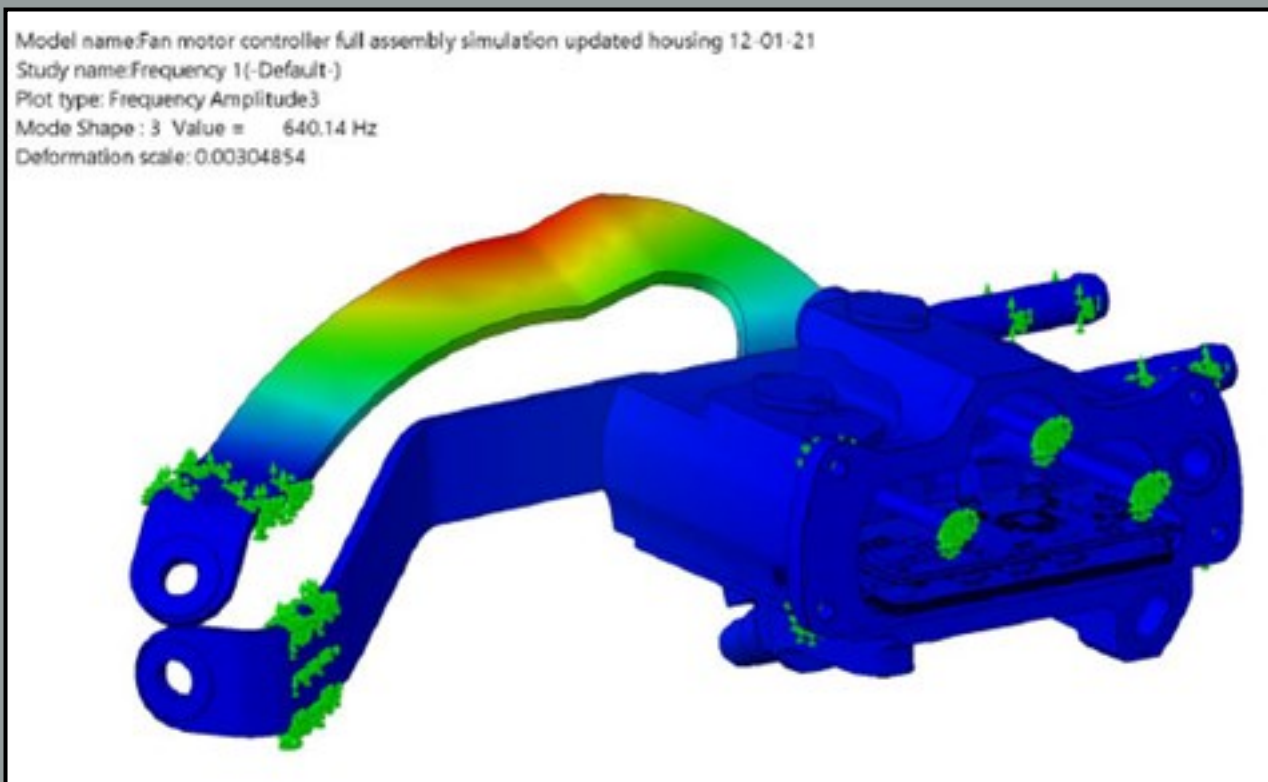

A deformed plot of the Fan Controller Unit showing peak deflection and energy in unsupported sections for this mode shape.